



HANDS FREE / BARRIER FREE  
VERSACOOLER® II

## PWEBF (Hands-Free VersaFiller Retrofit Kit)

### Suggested Specification

When retrofitted to either the P8AC or P8AM, the PWEBF Bottle Filler has independent hands free activation. Key VersaFiller components shall contain Freshield, which utilizes a silver-based antimicrobial compound that reduces the growth of micro-organisms and mildew to protect the surfaces from discoloration, odors and degradation. Unit shall include filter monitor and bottle counter. VersaFiller cabinet finish is Brushed Stainless Steel.

When retrofitted to either the P8AC or P8AM the VersaFiller models satisfy CABO/ANSI A117.1 and these water coolers comply with ADA requirements when properly installed. Units also meet guidelines for children's accessibility providing the floor to orifice height is 30 inches and proper clear floor space is provided for frontal approach.

### Standard Features

- > Waterways Are Lead-Free In Materials & Construction
- > VersaFiller has Independent Hands Free Activation
- > Integrated back-lit bottle counter
- > Built in filter monitor
- > Heavy Duty Steel Frame
- > Surface Mount Frame Assembly

### Finishes

- > VersaFiller Cabinet Finish is Brushed Stainless Steel

### Installation

- > Prior to roughing consult with local, state, and federal codes for proper mounting height.
- > Shipped with complete instructions and wall mounting brackets.



VersaFiller alcove is tall enough to accommodate most sizes of refillable water bottles on the market.

The PWEBF VersaFiller is designed to retrofit on existing Oasis P8AC and P8AM pressure cooler models



### Options

- > EZ/LZ Gasket 036689-201
- > Sunroc / HWS Gasket 036689-101

Models that this unit will not retrofit to: electric eye P8AC and P8AM units. Units with optional glass fillers must have the glass filler disconnected and removed.



ADA Compliant when retrofitted to either the P8AC or P8AM



Components in this fountain are lead free as defined by the Safe Drinking Water Act Amendments of 1986, and the Lead Contamination Control Act of 1988.

**Limited 1-Year Warranty** (Continental limits of the United States and Canada): 1 year on most component parts Detailed warranty certificate enclosed with each water cooler; sample available upon request.

**Export Warranty:** One year on component parts. Detailed warranty certificate enclosed with each drinking fountain; sample copy available upon request.

Product to be Certified to NSF/ANSI Standard 61, Annex G (weighted average lead content of  $\leq 0.25\%$ ) and is in compliance with California's Health & Safety Code Section 116875 (commonly known as AB1953). Models covered by this specification comply with all known Plumbing Codes. Product to be listed by Underwriters' Laboratories to U.S. and Canadian standards.

Model	50° F Drinking Water 90° F Ambient Air Temp*			Hot 'N Cold™ Model	115 Volts, 60 HZ			Glass Filler Acc. Option	Cabinet Color Finish	Net Wt. Approx.
	Rated Capacity GPH	Base Rate GPH	Pre-Cooler		Compr. HP	Full Load Amps	Rated Watts			
PWEBF			No	No		.10	7	No		10 Lbs.

\* Industry Standard Rating Condition 80° F inlet water temperature. \*NSF Pending. \*UL Pending.

Specifications subject to change without notice

# Oasis® PWEBF VersaFiller Retrofit kit with P8AC (not included).

Rough-in drawing is shown with a P8AC unit in order to show the proper height of the unit when retrofitted to the parent unit and height from the floor in order to comply with ADA standards. THE P8AC UNIT IS NOT INCLUDED WITH THE PURCHASE OF THE PWEBF.

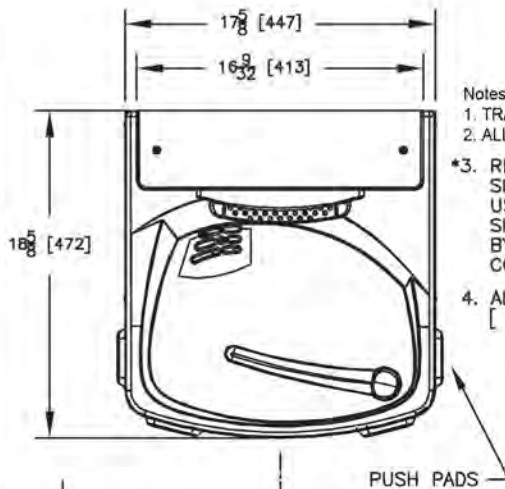

**Notes:**

1. TRAP, STOP VALVE AND ELECTRICAL OUTLET NOT FURNISHED
2. ALLOW 4 INCHES [ 102 mm ] MIN. PER SIDE FOR VENTILATION
- \*3. RECOMMENDED ADULT BARRIER FREE HEIGHT INSTALLATION SHOWN. REDUCE HEIGHT BY 3 INCHES FOR INSTALLATION USED PRIMARILY BY CHILDREN AGES 12 AND YOUNGER. I SHALL ALSO HAVE A MINIMUM CLEAR FLOOR SPACE 30[7 BY 48[1220]. ADJUST VERTICAL DIMENSIONS AS REQ'D TO COMPLY WITH FEDERAL, STATE, AND LOCAL CODES.
4. ALL DIMENSIONS ARE IN INCHES. DIMENSIONS IN BRACKET [ ] ARE IN MILLIMETERS.

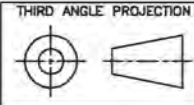
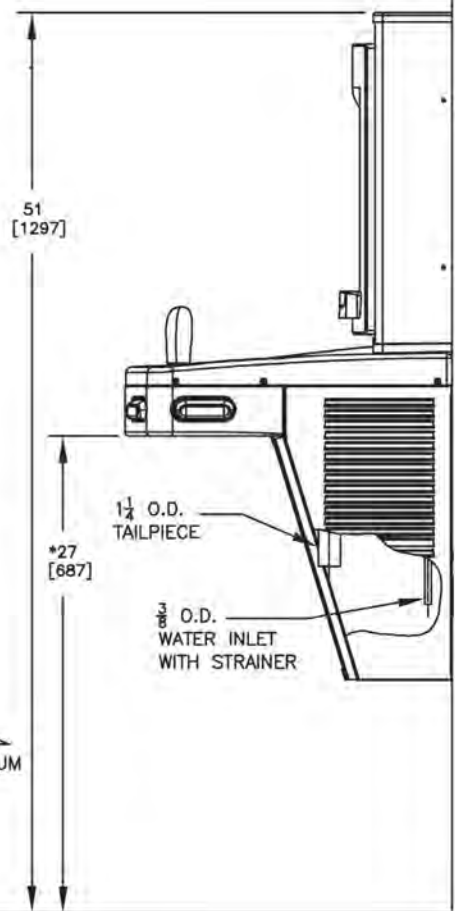
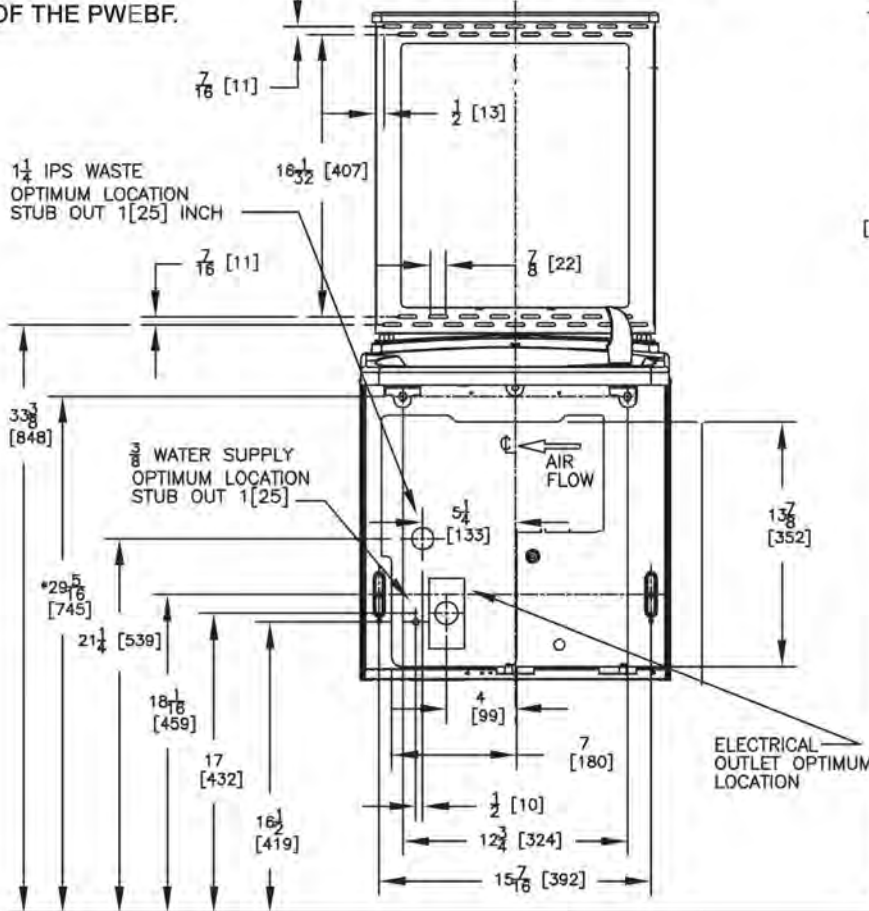

ROUGHING-IN AND DIMENSIONAL DRAWING